

## 성능곡선도 CMF 2 60Hz

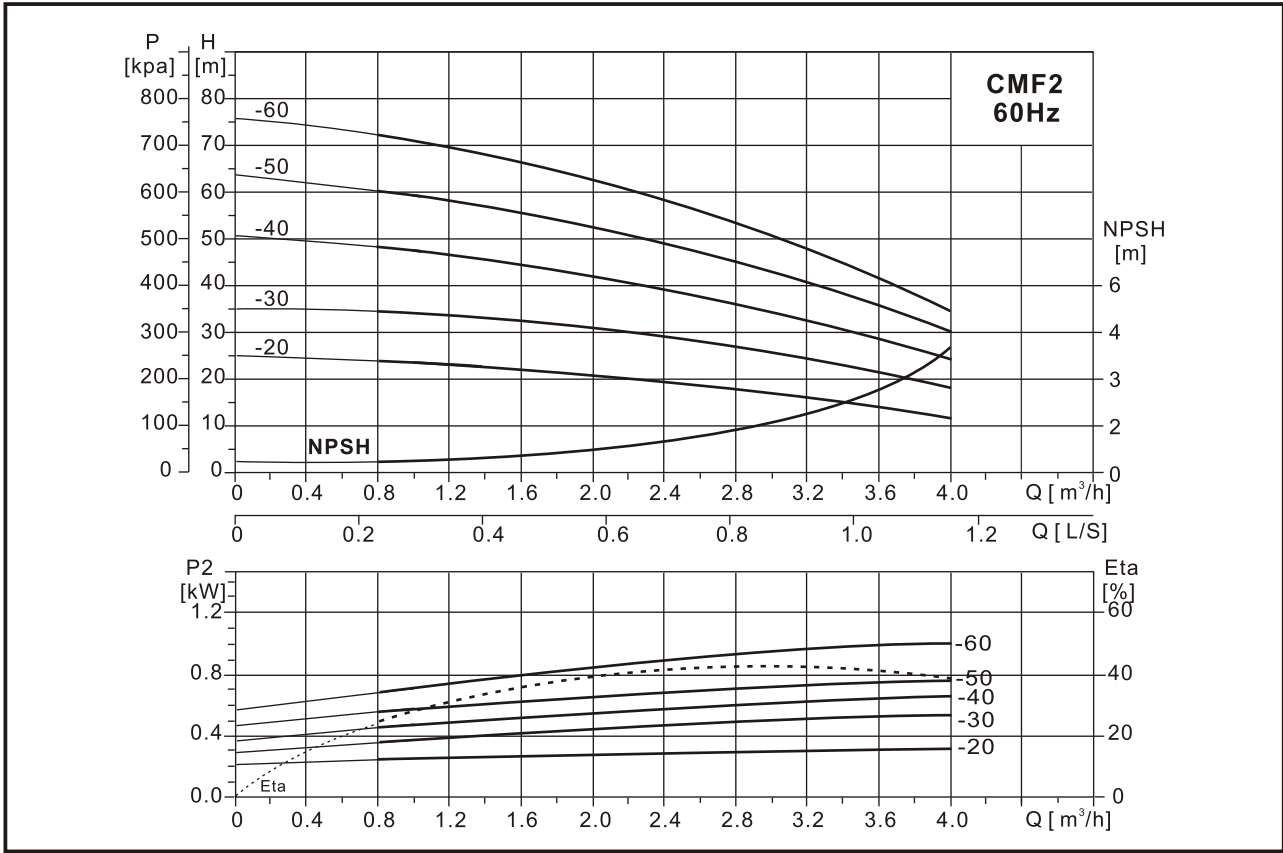

## Performance table

Model		Driving motor P <sub>2</sub> (kW)	Q (m <sup>3</sup> /h)	0.8	1.2	1.6	2.0	2.4	2.8	3.2	3.6	4.0
Single Phase	Three Phase			H (m)								
CMF2-20	CMF2-20T	0.37	H (m)	24	23	22	20	19	17	16	14	12
CMF2-30	CMF2-30T	0.55		36	35	33	31	29	26	24	21	18
CMF2-40	CMF2-40T	0.75		48	47	44	42	38	35	32	28	24
CMF2-50	CMF2-50T	0.75		60	58	55	51	47	43	40	33	30
CMF2-60	CMF2-60T	1.0		71	70	66	63	58	53	48	41	36

## 외형도 60Hz

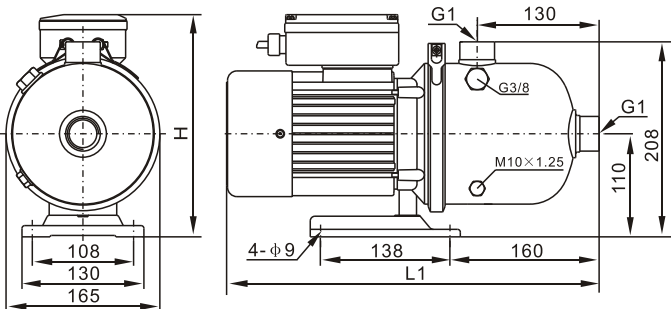

Model	Size(mm)				Weight (kg)
	Single Phase		Three Phase		
	L1	H	L1	H	
CMF2-20(T)	405	236	405	214	9
CMF2-30(T)	405	236	405	214	10
CMF2-40(T)	405	236	405	214	10.5
CMF2-50(T)	405	236	405	214	11
CMF2-60(T)	405	236	405	214	12